

Keeping Profit on Track with Wheel Alignment

Case Study



Company: Kidds Transport
Location: Lancaster
Fleet Size: 30

Company: Co-operative Retail
Logistics Distribution
Location: Wakefield
Fleet Size: 30

1 Keeping profit on track with wheel alignment

If the wheels on trucks are misaligned, even by only a small degree, it can have an adverse effect on both tyre wear and fuel consumption, as the engine has to work harder to make the vehicle move.

Visible signs of wheel misalignment include wear on the tyre shoulder or an uneven wear over the tyre tread. Wheels can be out of alignment for a number of reasons, for example, a steering joint may have been replaced, the vehicle may have nudged a kerb, or the vehicle might regularly run off-road, over uneven ground.

To reduce tyre wear and avoid unnecessary fuel use, wheels should be realigned to within specific tolerances.

For many operators, wheel alignment has been an integral part of a preventive maintenance programme for some time. Basic alignment methods use a mechanical gauge with manual calibration being carried out by eye.

As fuel and tyre costs have increased, some operators have turned to laser technology as a more accurate method of wheel alignment.

The following case studies of Kidds Transport and Co-operative Retail Logistic (CRL) Distribution provide information on how each company has benefited from incorporating laser wheel alignment into their preventive maintenance programmes.



Wheel alignment using laser technology

2 What are the aims of wheel alignment?

For steered axles;

- ➔ To achieve correct 'toe in'/'toe out' (the degree to which wheels are turned towards the centre or towards the outside of the vehicle)

For drive and trailer axles to make them;

- ➔ Square to centre line of the chassis
- ➔ Parallel across the axle
- ➔ Parallel between axles

Using laser equipment, the procedure aims to align to within 0.15° accuracy.

3 What are the potential benefits of ensuring wheels are accurately aligned?

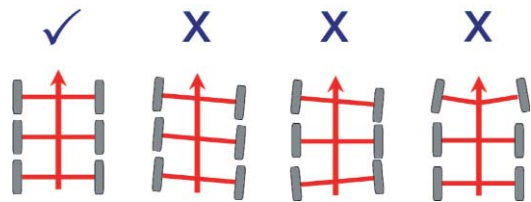

Figure 1: Correct wheel alignment

The potential benefits of carrying out wheel alignment are:

- ➔ Reduced fuel usage (a 1° misalignment on one axle could increase fuel consumption by around 5%)
- ➔ Improved tyre life (a 0.5° misalignment can reduce tyre life by up to 50%)
- ➔ Reduced carbon dioxide and other harmful emissions
- ➔ Less stress on mechanical components
- ➔ Improved driver comfort and safety
- ➔ Reduced potential for tyre overheating

4 The process of laser wheel alignment

Figure 2 (courtesy of Josam - wheel alignment manufacturers) Laser wheel alignment to help ensure vehicle symmetry

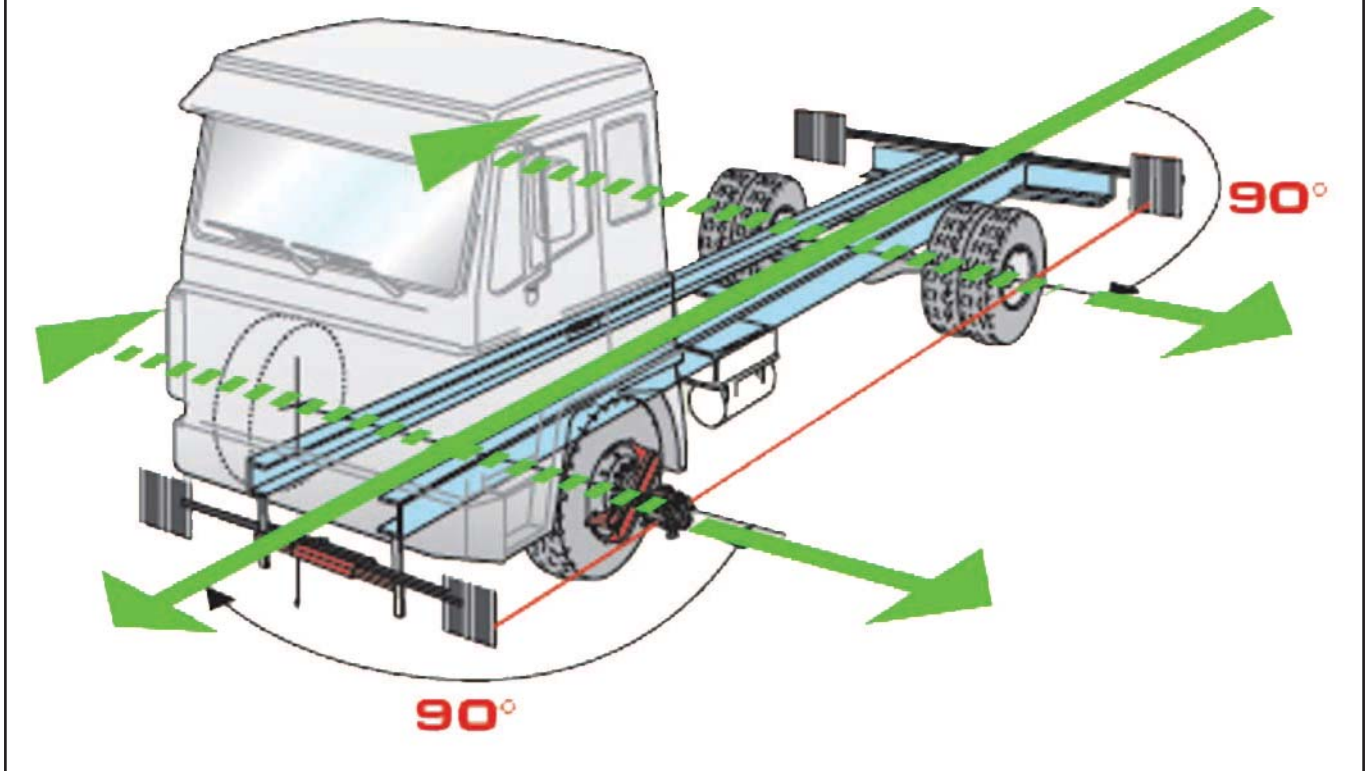

The process of laser wheel alignment involves fitting the vehicle at the front and rear with bars with measuring gauges attached. Devices are then fitted to each wheel, complete with laser lights. These laser lights on each wheel are lined up with the gauges on the front and rear bars, to measure the amount of 'toe in' and 'toe out' of each wheel. Having taken these measurements, simple adjustments can be made and wheel realignment achieved. Figure 2 illustrates the procedure.



Laser light devices fitted to each wheel



Bars with measuring gauges fitted front to rear

5 How often should wheel alignment be carried out?

Wheel alignment can offer most benefit if repeated at least every 12 months. The two companies featured in this case study incorporate wheel alignment in their annual pre-MoT inspection.

Between planned annual wheel alignment procedures, regular vehicle safety inspections include monitoring of tyre wear. If noticeable uneven wear is detected at any time during the year, realignment is carried out.

It may also be beneficial to carry out the process before a new vehicle is put into service, to ensure all wheels are accurately aligned. If a vehicle has been involved in an accident and repaired, calibration should be rechecked before the vehicle is put back into service.

6 How much might laser wheel alignment cost?

Calibration costs vary depending on the type and number of vehicles in the fleet.

Description	Cost
Single axle steering	£65
Twin axle steering	£110
Additional other axles	£45 per axle
Centralise steering box	£36
Full geometry test (all axles and steering box)	£200

Table 1: Example of current charges for a company with a single vehicle

Case Study 1 - Kidds Transport



Kidds Transport 6 axle articulated tanker

Kidds Transport is a Lancaster-based company employing 30 drivers and runs a 12-hour operation from Monday to Friday.

The company's fleet consists of:

- ➔ 26 tractor units
- ➔ 80 semi trailers
- ➔ 4 rigid lorries

The rigid vehicles perform palletised daily deliveries on a multi-drop operation in and around Lancaster, Morecombe, Barrow and Kendal.

"We currently have one vehicle due for MoT. It is two years old and has travelled 225,000 kms on its original tyres. We expect another 100,000 kms from this set of tyres when the wheels are changed from the front steer axle to the second steer axle. This is only possible through regular wheel alignment to prolong tyre life."

Martin Morris, Fleet Engineer, Kidds Transport

Some of the articulated vehicles carry third party goods, again mainly palletised, from manufacturers to regional distribution centres nationwide. The tanker semi-trailers in the fleet are used to transport liquid chemicals. Maintenance of the fleet is carried out on site at the depot by the company's own workshop staff.

In an attempt to improve fuel efficiency, reduce wear and tear on vehicle components and increase tyre life, Kidds Transport first made the decision to implement a wheel alignment programme in 1996. The company continues to benefit from the process on an ongoing basis.

"Pulling the hire trailer was like having a load on, compared to the easy movement of our own trailers which regularly undergo wheel alignment."

A Kidds Transport Long Distance Driver

"The drivers are less fatigued when not fighting to keep the vehicle in a straight line."

Martin Morris, Fleet Engineer, Kidds Transport



Uneven tyre wear due to misalignment

The tyre in this photograph has completed 220,000 kms and shows some uneven wear due to misalignment. However, if action is taken to rectify the problem then the expected life could be extended to over 300,000 kms.

"It only takes half an hour to carry out the calibration and the engineer fits in with our service schedules."

Martin Morris, Fleet Engineer, Kidds Transport

The benefits

Kidds Transport reports:

- ➡ Fuel performance improved on one vehicle from approximately 6.5 miles per gallon (mpg) to approx 9 mpg.
- ➡ The average fuel consumption across the fleet is now approximately 8.5 mpg, resulting in fuel savings of
 - 3.8% - 18.6% on articulated lorries
 - 3.0% - 11% on rigid lorries
- ➡ Steered axle tyre tread life is up from 180,000 kms to 220,000 kms (an increase of 22% in tyre life)
- ➡ Drive axle tyre tread life up from 280,000 kms to 310,000 kms (an actual increase of over 10% in tyre life)
- ➡ Super single tyre tread life up from 65,000 kms to 75,000 kms (an increase of 15% in tyre life)
- ➡ Added safety, as aligned tyres are less likely to overheat
- ➡ Drivers report reduced fatigue as vehicles are easier to drive

Case Study 2 - Co-operative Retail Logistics Distribution (CRL Distribution)

CRL Distribution delivers fresh, chilled and frozen foods to Co-op retail outlets. One of its key Northern depots is at Ossett, near Wakefield, West Yorkshire. This depot operates 24 hours per day, delivering mainly along the M62 corridor between Manchester and Hull.



CRL Distribution 6 axle articulated box

The depot's fleet consists of:

- ➡ 7.5 tonne rigid hire vehicle (1 unit)
- ➡ 18 tonne four-wheel rigids (4 units)
- ➡ 26 tonne six-wheel rigids (21 units)
- ➡ 38 tonne articulated vehicles (4 units)

The depot currently employs 55 drivers, divided across day, late and night shifts. Drivers work an 8-12 hour shift on a three or four day rota.

Wheel alignment was first carried out in 1994 on the Ossett depot fleet and due to its success, has since expanded into all depots which have an in-house maintenance team.

CRL first discovered the value of laser alignment when the depot identified a particular problem with a vehicle which had a tyre life of only 45,000 kms. Normal checks failed to identify the root cause of the problem. The wear on the tyres was noticeable at each regular safety inspection and the manual mechanical tracking gauge method originally used for wheel alignment failed to show any deviation.

However, owing to the sensitivity of the laser wheel alignment process, the fault was identified and rectified. The fault was found to be that the nearside front wheel was misaligned. Following positive results at this depot the company now puts all of its vehicles through wheel alignment at every pre-MoT inspection at all 20 depots.



Tractor unit undergoing wheel alignment

"We were having problems of shortened tyre life with one vehicle and could not rectify the problem with our equipment. The wheel alignment engineer called in and we asked him to demonstrate the process on this vehicle. The misalignment fault was found almost immediately and rectified."

Stuart Brooks, Fleet Engineer, CRL Distribution

The benefits

CRL Distribution reports:

- ➡ Steered axle tyre tread life is up from 70,000 kms to 140,000 kms (an increase of 100% in steer tyre life)
- ➡ Drive axle tyre tread life up from 140,000 kms to 160,000 kms (an actual increase of 14% in tyre life)
- ➡ Added vehicle safety, as aligned tyres do not overheat as readily
- ➡ Reduced driver fatigue as vehicles are easier to drive
- ➡ Reduced wear on the mechanical parts

7 Fleet fuel and tyre savings - worked example

The worked example below outlines illustrative savings and potential benefits which might be achieved through a wheel alignment programme. The costs of wheel alignment and fuel are indicative and relate to the fact that larger fleets may be eligible for discounts.

Key assumptions

Fleet Parameters	
No. of tractor units	50
Average no.of axles per tractor	3
No. of trailers	100
Average no. of axles per trailer	3
Average annual mileage per vehicle	100,000 kms
Percentage of vehicles misaligned	30%
Average wheel misalignment	0.5°
Wheel Alignment Costs	
Alignment costs for tractor units per vehicle	£140
Alignment costs for trailers per vehicle	£130
Tyre Parameters	
Average tyre life	200,000 kms
Tyres cost per axle	£600
Fuel Parameters	
Fuel cost	£0.94 per litre
Net cost (ex VAT)	£0.80 per litre
Fuel economy	34 litres per 100 kms
CO ₂ per litre	2.68 kg

Annual savings per fleet

Total reduction in fuel costs	£68,750 (5.1%)
Total reduction in tyre costs	£21,216 (7.9%)
Potential total saving	£89,966 (5.5%)
Cost of alignment programme	£20,000
Potential net saving	£69,966 (4.3%)
Total amount of fuel saved	85,937 litres (5.1%)
Total reduction in CO ₂	230 tonnes
Total Net Saving	£69,966 (4.3%)

8 Conclusion

It makes sound operational and financial sense to make sure that the wheels on your vehicles are correctly aligned.

A programme of laser wheel alignment, implemented as part of a preventive maintenance programme, can lead to increases in tyre life and improved fuel efficiency. Correct wheel alignment can also lead to less wear and tear on vehicle components and reduced driver fatigue, as vehicles become easier to drive.

Special thanks to Steertrak, Kidds Transport and CRL Distribution for their assistance in the production of this case study.

Saving Fuel



Fuel Management Guide

The definitive guide to improving the fuel performance of your fleet. This guide provides information, advice and suggestions on how to improve the fuel efficiency of your vehicle fleet.

Operational Efficiency



Make Back-loading Work for You

A guide showing how to find and choose profitable back-loads.

Developing Skills



Safe Driving Tips

Written especially for commercial drivers, this pocket-sized guide provides essential safety hints and tips on all aspects of the job.

Performance Management



In Fleet Trials of Fuel Saving Interventions for Trucks

For managers investigating the use of fuel saving interventions or setting up their own in-fleet trials. This guide shows how to establish the potential performance of fuel saving devices in your fleet.

Equipment and Systems



Truck Aerodynamic Styling

Practical information on aerodynamically effective trucks and appropriate add-on features.

Public Sector



Efficient Public Sector Fleet Operations

Baseline information on understanding, designing and running public sector fleets. Case studies show performance measurement.

Freight Best Practice publications can be obtained FREE of charge by calling the Hotline on 0845 877 0 877. Alternatively, they can be downloaded from the website www.freightbestpractice.org.uk

